

Relation between decoherence and spontaneous symmetry breaking in many-particle qubits

Jasper van Wezel,¹ Jan Zaanen,¹ and Jeroen van den Brink^{1,2}

¹*Institute-Lorentz for Theoretical Physics, Universiteit Leiden, P.O. Box 9506, 2300 RA Leiden, The Netherlands*

²*Institute for Molecules and Materials, Radboud Universiteit Nijmegen, P.O. Box 9010, 6500 GL Nijmegen, The Netherlands*

(Received 15 June 2006; revised manuscript received 7 August 2006; published 27 September 2006)

We have recently shown that there is a limit to quantum coherence in many-particle spin qubits due to spontaneous symmetry breaking. These results were derived for the Lieb-Mattis spin model. Here we will show that the underlying mechanism of decoherence in systems with spontaneous symmetry breaking is in fact more general. We present here a generic route to finding the decoherence time associated with spontaneous symmetry breaking in many-particle qubits, and subsequently we apply this approach to two model systems, indicating how the continuous symmetries in these models are spontaneously broken and discussing the relation of this symmetry breaking to the thin spectrum. We then present in detail the calculations that lead to the limit to quantum coherence, which is due to energy shifts in the thin spectrum.

DOI: [10.1103/PhysRevB.74.094430](https://doi.org/10.1103/PhysRevB.74.094430)

PACS number(s): 75.10.-b, 75.45.+j, 03.65.Yz

I. INTRODUCTION

Recently we have shown that spontaneous symmetry breaking imposes a fundamental limit for the time that a large spin system can stay quantum coherent. This universal time scale is $t_{\text{spon}} \approx 2\pi N\hbar / (k_B T)$, given in terms of the number of microscopic degrees of freedom N , temperature T , and the constants of Planck (\hbar) and Boltzmann (k_B).¹ We analyzed this quantum decoherence process in terms of the exactly solvable Lieb-Mattis spin model, which is known to describe a symmetry broken macroscopic antiferromagnet in equilibrium. Within this spin model we investigated the dynamical reduction of quantum physics to classical behavior via spontaneous symmetry breaking. The goal of this paper is to present a self-contained, detailed description and explanation of the decoherence process caused by spontaneous symmetry breaking.

The fact that spontaneous symmetry breaking can lead to decoherence on a time scale t_{spon} might come as a surprise. For a macroscopic body at room temperature, $\hbar / (k_B T)$ is of order 10^{-14} sec, which is quite a short time. However, multiplying with Avogadro's number $N \approx 10^{24}$, yields $t_{\text{spon}} \approx 10^{10}$ sec, corresponding to a couple of centuries. Given all other sources of decoherence for such a large macroscopic body, this is surely not a relevant time scale. However, the mesoscopic quantum qubits of contemporary interest are typically much smaller and the intrinsic coherence time might be reached in the near future. The counterintuitive feature of this intrinsic decoherence mechanism linked to classical equilibrium is that it starts to matter when systems become small.

The many-particle qubits that motivate us to study decoherence due to spontaneous symmetry breaking are realized in a number of mesoscopic solid state systems. For instance, by engineering aluminum on a submicron length scale, superconducting flux qubits, and Cooper pair boxes can be manufactured. The flux qubit is a Josephson device that can be brought into a quantum superposition of two electrical currents: a left and a right circulating current.^{2,3} Typically this current is carried by $N \sim 10^6$ Cooper pairs. A Cooper pair

box on the other hand is a superconducting island, containing $N \sim 10^8$ electrons, which can be brought in superposition of two states with a different number of Cooper pairs.^{4,5} Magnetic many-particle qubits are for instance realized in molecular nanomagnets. Molecules with large magnetic moments can be brought into a superposition of directions of magnetization. A well studied example is Mn¹² acetate, a molecule that contains 12 manganese atoms, coupled together to form a total spin of $S=10$. The molecule can be brought into a superposition of states with $S^z = +10$ and $S^z = -10$ and coherent Rabi oscillations of the magnetization are observed.⁶ An even larger molecule is ferritin, that contains about 4500 Fe³⁺ ions.⁷ If the total magnetic moment of a ferritin molecule is brought into a coherent superposition, this corresponds to a superposition of $N \sim 10^2$ spins. For these mesoscopic superconducting and magnetic qubits the limit in coherence due to spontaneous symmetry breaking is relevant.

This paper is organized as follows. We first introduce the general notion of spontaneous symmetry breaking and the thin spectrum. We illustrate these concepts by the elementary example of a harmonic crystal that breaks translational symmetry. We then show how the presence of a thin spectrum can cause decoherence. Again we clarify the concept by describing a theoretical setup in which we use the crystal as a qubit. After that we switch to the more involved example of the (non-Abelian) antiferromagnet. We first recapitulate the properties of the Lieb-Mattis model⁸ and determine its symmetric and symmetry-broken eigenstates. Subsequently we will use the model to determine the effect of spontaneous symmetry breaking on quantum coherence. For this purpose we devise a generic gedanken experiment by coupling a two spin singlet state to the macroscopic Lieb-Mattis antiferromagnet. We calculate the exact time evolution of this many-body quantum superposition. Our main result on decoherence follows from the evaluation of the reduced density matrix of the superposition by tracing out the thin states. Finally we will then discuss what it reveals regarding spontaneous symmetry breaking in more general Heisenberg-like spin Hamiltonians.

A. Spontaneous symmetry breaking

Due to the homogeneity of space, the laws of nature possess translational invariance. This invariance implies the classical law of conservation of momentum. Likewise, space being isotropic enforces rotational symmetry on the laws of physics, implying conservation of angular momentum. In quantum mechanics the power of symmetry is even greater: the translational and rotational invariance of the laws of nature taken at face value, should imply that any physical quantum object that obeys these laws, has translational and rotational symmetry. However, daily experience shows that this conclusion is nonsensical. If the universe around us and everything in it would be translationally and rotationally invariant, it would look the same at all places and in all directions: we would be surrounded by a “quantum mist,” while human observers should be dissolved in this quantum fog as well. However, in the real world translational and rotational symmetry are manifestly broken. The fundamental difference between quantum and classical physics lies in the role of symmetry. Dealing with an exact quantum mechanical eigenstate, all configurations equivalent by symmetry should have exactly the same status in principle, while in a classical state one of them can be singled out. In the example above, given that space is translationally invariant, a quantum object should be in an eigenstate of total momentum, being spread out with equal probability over all of space. In the classical limit however, it takes a definite position. The explanation of this “spontaneous symmetry breaking” as a ramification of the singular nature of the thermodynamic limit is one of the central achievements of quantum condensed matter physics.⁹ One imagines a symmetry breaking “order parameter field” B (e.g., a potential singling out a specific position in space). Upon sending B to zero before taking the thermodynamic limit ($N \rightarrow \infty$) one finds the exact quantum groundstate respecting the symmetry. However, taking the opposite order of limits one finds that the classical state becomes fact. Although the concept of spontaneous symmetry breaking was originally introduced in the context of quantum magnetism in solid state physics,⁹ spontaneous symmetry breaking is a general phenomenon, that is just as relevant in other fields, including elementary particle physics and cosmology.¹⁰

Let us first consider how spontaneous symmetry breaking arises in a crystalline lattice to continue in the next section with antiferromagnets. Consider the textbook example of a harmonic crystal, with the Hamiltonian

$$H = \sum_j \frac{\mathbf{p}_j^2}{2m} + \frac{\kappa}{2} \sum_j (\mathbf{x}_j - \mathbf{x}_{j+1})^2, \quad (1)$$

where j labels all N atoms in the lattice, which have mass m , momentum \mathbf{p}_j , and position \mathbf{x}_j . We consider here only a one-dimensional chain of atoms, but all of the following can be straightforwardly generalized to higher dimensions as well. The harmonic potential between neighboring atoms is parametrized by κ ; it turns out that the results on spontaneous symmetry breaking that follow are equally valid for anharmonic potentials. Let us first identify the collective dynamics which describe the spontaneous symmetry breaking of this short-ranged microscopic Hamiltonian.

In the standard treatment of the quantum crystal one begins by introducing alternative coordinates, which are the displacements of atoms from their equilibrium position. Then, after a Fourier transform the eigenstates of this Hamiltonian are easily found. We take a slightly longer route by introducing bosonic phonon operators from the very beginning and diagonalizing the quadratic part of the Hamiltonian by performing a Bogoliubov transformation at the end. In doing so we do not have to introduce any equilibrium position of the atoms. Instead we can keep track of the center of mass motion of the crystal as a whole, and this brings to the fore the thin spectrum in a natural manner. Moreover we can use the exact same procedure in the next section to find the collective order parameter dynamics for antiferromagnets.

The momentum and position operators are expressed in terms of bosonic operators as follows:

$$p_j = iC \sqrt{\frac{\hbar}{2}} (b_j^\dagger - b_j); \quad x_j = \frac{1}{C} \sqrt{\frac{\hbar}{2}} (b_j^\dagger + b_j), \quad (2)$$

so that the commutation relation $[x_j, p_{j'}] = i\hbar \delta_{j,j'}$ is fulfilled. We choose $C^2 = \sqrt{2m\kappa}$ so that the Hamiltonian reduces to

$$H = \frac{\hbar}{4} \sqrt{\frac{2\kappa}{m}} \sum_j 2(b_j^\dagger b_j + b_j b_j^\dagger) - (b_j^\dagger + b_j)(b_{j+1}^\dagger + b_{j+1}) \quad (3)$$

and after a Fourier transformation

$$H = \hbar \sqrt{\frac{\kappa}{2m}} \sum_k \left[A_k b_k^\dagger b_k + \frac{B_k}{2} (b_k^\dagger b_{-k}^\dagger + b_k b_{-k}) + 1 \right],$$

where $A_k = 2 - \cos(ka)$, $B_k = -\cos(ka)$, and a is the lattice constant. This Hamiltonian is still not diagonal, since the terms $b_k^\dagger b_{-k}^\dagger$ and $b_k b_{-k}$ create and annihilate two bosons at the same time. We get rid of these terms by a Bogoliubov transformation (see the Appendix). After this the Hamiltonian in terms of transformed boson operators $\beta_k = \cosh(u_k) b_{-k} + \sinh(u_k) b_k^\dagger$ is

$$\begin{aligned} H &= \hbar \sqrt{\frac{\kappa}{m}} \sum_k \left[2 \sin|ka|/2 \left(\beta_k^\dagger \beta_k + \frac{1}{2} \right) + \frac{1}{4} \sqrt{2} \cos(ka) \right] \\ &= 2\hbar \sqrt{\frac{\kappa}{m}} \sum_k \sin|ka|/2 \left[n_k + \frac{1}{2} \right], \end{aligned} \quad (4)$$

since $\sum_k \cos k = \frac{N}{2\pi} \int_{-\pi}^{\pi} dk \cos k = 0$.

This result seems to coincide with the textbook Hamiltonian which we would have obtained if we had followed the conventional route of Fourier transforming the Hamiltonian for the displacements, and then quantizing it. However, the Bogoliubov transformation has the advantage that it brings to the fore a rather subtle point. When $k \rightarrow 0$ the excitation energy $\omega_k \rightarrow 0$ and the two parameters in the Bogoliubov transformation diverge: $\sinh(u_k) \rightarrow \infty$ and $\cosh(u_k) \rightarrow \infty$. Precisely at $k=0$ the canonical transformation is no longer well defined. We therefore should investigate the bosonic terms in the Hamiltonian with $k=0$ separately. This zero momentum part of the Hamiltonian describes the obvious fact that the crystal as a whole carries a kinetic energy associated with the

combined mass of all of its constituents, and is given by

$$\begin{aligned} H_{\mathbf{k}=0} &= \hbar \sqrt{\frac{\kappa}{2m}} \left(b_0^\dagger b_0 - \frac{1}{2} (b_0^\dagger b_0^\dagger + b_0 b_0) + 1 \right) \\ &= \hbar \sqrt{\frac{\kappa}{2m}} \left[1 - \frac{1}{2} (b_0^\dagger - b_0)^2 \right], \end{aligned} \quad (5)$$

where $(b_0^\dagger - b_0)^2 = \frac{-2}{\hbar\sqrt{2m\kappa}} \mathbf{p}_0^* \mathbf{p}_0$ so that

$$H_{\mathbf{k}=0} = \frac{P_{tot}^2}{2Nm} + \text{constant}, \quad (6)$$

where $\mathbf{p}_{tot} \equiv \sum_j \mathbf{p}_j = \sqrt{N} \mathbf{p}_{\mathbf{k}=0}$ is the total momentum of the entire system, or equivalently, its center of mass momentum. When N is large, this Hamiltonian has states that are very low in energy. These states in fact form the thin spectrum of the harmonic crystal. We call this part of the spectrum *thin* because it contains so few states of such low energy that its contribution to the free energy in the thermodynamic limit completely disappears (see the Appendix). In turn, this implies that these thin spectrum states do not contribute to any thermodynamically measurable quantities such as, for instance, the specific heat of the crystal. Their effect on the properties of the crystal is thus increasingly subtle, but its existence can nonetheless have profound consequences. In classical systems this thin spectrum is absent: it is quantum mechanics that generates it. About a decade ago the deep meaning of the thin spectrum for interacting quantum systems became clear and consequently its explicit mathematical structure was determined.^{11,12}

The groundstate of the Hamiltonian at $\mathbf{k}=0$, which governs the collective behavior of the crystal as a whole, obviously has total momentum zero. It thus has no uncertainty in total momentum and maximum uncertainty in total position: the translational symmetry is unbroken. Symmetry breaking can occur if we add to the Hamiltonian of Eq. (6) a symmetry breaking field of the form $B \mathbf{x}_{tot}^2/2$, where the center of mass coordinate is $\mathbf{x}_{tot} \equiv \sum_j \mathbf{x}_j$. This yields a harmonic oscillator equation for the collective position coordinate. Its well known groundstate wave function is

$$\psi_0(x_{tot}) = \left(\frac{m\omega N}{\pi\hbar} \right)^{1/4} e^{-\frac{m\omega N}{2\hbar} x_{tot}^2}; \quad \omega = \sqrt{\frac{B}{mN}}. \quad (7)$$

This state describes a wave packet for the center of mass coordinate in real space, which of course corresponds to an equivalent superposition of total momentum states: the symmetry breaking field B couples the different thin spectrum states of the crystal. For a vanishing symmetry breaking field B and finite number of atoms we have $\omega N \rightarrow 0$ and the collective coordinate is completely delocalized, as before: $\psi_0(x_{tot}) = \text{const.}$ But taking the thermodynamic limit ($N \rightarrow \infty$) in the presence of a finite symmetry breaking field gives $\omega N \rightarrow \infty$ and the center of mass position becomes completely localized in the center of the potential well [$\psi_0(x_{tot}) = \delta_{x_{tot},0}$], even if at the end the symmetry breaking field is sent to zero. As we already pointed out, such a singular limit characterizes spontaneous symmetry breaking; in this particular case the translational symmetry of the crystal as a

whole is spontaneously broken. The occurrence of a thin spectrum which consists of the states associated with the quantum mechanics of the macroscopic body as a whole is a universal notion. Whenever a system exhibits a continuous symmetry which is broken in the classically realized, macroscopic state, then consequently there must be a spectrum of states associated with the symmetry-restoring fluctuations of the order parameter as a whole. The smallness of the energy spacing within the thin spectrum warrants the order parameter dynamics of macroscopic bodies to take place on a time scale much larger than anything observable.

B. Decoherence

To study the effect of the thin spectrum on the coherence of many particle qubits, let us first investigate the dynamics of such a qubit in the most general terms. Consider a many particle system that is large enough to display a spontaneously broken continuous symmetry, but small enough to be used as a qubit. This qubit will then have a thin spectrum which we can label by the quantum number n . At the same time the system must have two accessible quantum states that can be used as the qubit states, and which can be labeled by the quantum number m . Because we have no experimental control over the thin spectrum states, we will have to start out the experiment with a thermal mixture of those states:

$$\rho_{t < t_0} = \frac{1}{Z} \sum_n e^{-\beta E_0^n} |0, n\rangle \langle 0, n|, \quad (8)$$

where ρ_t is the density matrix, E_m^n is the energy of the state $|m, n\rangle$ and where, by definition, the partition function is $Z = \sum_n e^{-\beta E_0^n}$ and $\beta^{-1} = k_B T$. To begin using this qubit in a quantum computation we will typically have to prepare it in some coherent superposition of the states in the two level system. To do this we apply a rotation that takes the state $|0, n\rangle$ into the state $\sqrt{1/2}(|0, n\rangle + |1, n\rangle)$ for all values of n . The resulting density matrix then is given by

$$\begin{aligned} \rho_{t=t_0} &= \frac{1}{2Z} \sum_n e^{-\beta E_0^n} (|0, n\rangle \langle 0, n| + |0, n\rangle \langle 1, n| + |1, n\rangle \langle 0, n| \\ &\quad + |1, n\rangle \langle 1, n|). \end{aligned} \quad (9)$$

If we know the Hamiltonian H which governs the dynamics of the qubit, then we can follow the time evolution of this density operator by applying the time evolution operator $U|m, n\rangle \equiv e^{-(i/\hbar)H(t-t_0)}|m, n\rangle = e^{-(i/\hbar)E_m^n(t-t_0)}|m, n\rangle$. We then find for the density matrix at $t > t_0$,

$$\begin{aligned} \rho_{t > t_0} &= U \rho_{t=t_0} U^\dagger = \frac{1}{2Z} \sum_n e^{-\beta E_0^n} (|0, n\rangle \langle 0, n| + |1, n\rangle \langle 1, n| \\ &\quad + [e^{-i/\hbar(E_0^n - E_1^n)(t-t_0)} |0, n\rangle \langle 1, n| + \text{H.c.}]), \end{aligned} \quad (10)$$

where H.c. denotes the Hermitian conjugate of its preceding term.

Experimentally the thin spectrum is as good as unobservable because of its extremely low energy and its vanishing thermodynamic weight (see the Appendix). We therefore have to trace these states out of the density matrix. This will

yield a reduced (observable) density matrix, defined by

$$\rho_{t>t_0}^{red} = \sum_j \langle j | \rho_{t>t_0} | j \rangle, \quad (11)$$

where the trace is over thin spectrum states labeled by j and $\langle j | m, n \rangle \equiv |m\rangle \delta_{j,n}$. Performing the trace, we find the following reduced density matrix in the basis of the states $|m\rangle$:

$$\rho_{t>t_0}^{red} = \frac{1}{2} \begin{bmatrix} 1 & \rho_{t>t_0}^{OD} \\ [\rho_{t>t_0}^{OD}]^* & 1 \end{bmatrix}, \quad (12)$$

where the off-diagonal matrix element is defined

$$\rho_{t>t_0}^{OD} \equiv \frac{1}{Z} \sum_n e^{-\beta E_0^n} e^{-(i\hbar)(E_0^n - E_1^n)(t-t_0)}. \quad (13)$$

If this off-diagonal matrix element vanishes at some time, then the qubit will have decohered at that time, due to the presence of the thin spectrum. In general $\Delta E_{thin} \equiv E_0^n - E_1^n$ will not be zero, and this shift in energy corresponds to a phase shift of the thin spectrum states. These phases will typically interfere destructively, lowering $\rho_{t>t_0}^{OD}$ and leading to dephasing and decoherence. The time scale for this decoherence process is set by the inverse of the involved energy scale, and will therefore be proportional to $\hbar / \Delta E_{thin}$.

For this dephasing to occur however, it is necessary that a finite number of thin spectrum states participates in the dynamics of decoherence. How many states do contribute to the process is governed by the Boltzmann factor $e^{-\beta E_0^n}$, which exponentially suppresses states of energy higher than $\sim k_B T / E_{thin}$ with E_{thin} the typical level spacing of the thin spectrum states. Putting these arguments together, one finds that the characteristic time scale on which $\rho_{t>t_0}^{OD}$ will vanish should be proportional to

$$t_{spon} \propto \frac{\hbar}{k_B T} \frac{E_{thin}}{\Delta E_{thin}}. \quad (14)$$

In the following sections we will calculate t_{spon} explicitly for a number of realizations of the many particle qubit. We will see that in the generic situation $\Delta E_{thin} \propto E_{thin} / N$ so that we find

$$t_{spon} \propto \frac{N\hbar}{k_B T}, \quad (15)$$

which is our main result.

II. THE CRYSTAL AS A QUBIT

As a first example of the influence of the thin spectrum on coherence, let us try to employ the harmonic crystal discussed in the introduction as a qubit. In order to do so we will have to define a set of two states that are to be used as the calculational states of the qubit. A simple choice for such a set could be to use the presence or absence of an interstitial

excitation. This leads to the definition of the state $|m=0\rangle$ describing the crystal with N atoms, and the state $|m=1\rangle$ which has one extra interstitial atom, and is described by the same model, but with $N+1$ atoms in the lattice. The thin spectrum is exactly as described in (6), so that the energy can be defined

$$E_m^n = \frac{n^2}{2M(N+m)} + \mu m, \quad (16)$$

where M is the mass of an atom, n labels states with different total momentum (which make up the thin spectrum), and μ is the chemical potential associated with adding an extra atom to the lattice.

We are now in the position to simply substitute this information into the general expression for the off-diagonal matrix element of the reduced density matrix (13), yielding

$$\rho_{t>t_0}^{OD} = \frac{1}{Z} e^{-(i\hbar)\mu(t-t_0)} \sum_n e^{-\beta n^2 / (2MN)} \times e^{-(i\hbar)n^2 / (2M)(1/N - 1/(N+1))(t-t_0)}. \quad (17)$$

The constant phase factor $e^{-(i\hbar)\mu(t-t_0)}$ does not contribute to the decoherence process, but the terms depending on n introduce phase shifts into the dynamics of the system, which lead to the disappearance of $\rho_{t>t_0}^{OD}$ over time. Upon introduction of $E_{thin} = 1 / (2MN)$ and $\Delta E_{thin} = 1 / [2MN(N+1)] \approx 1 / (2MN^2)$, a straightforward evaluation of the sum over thin spectrum states yields t_{spon} , defined as the half time for $|\rho_{t>t_0}^{OD}|$,

$$t_{spon} = \frac{2\pi\hbar}{k_B T} \frac{E_{thin}}{\Delta E_{thin}} = N \frac{2\pi\hbar}{k_B T}. \quad (18)$$

By using the crystal as a qubit in this way we have assumed that we can just ignore the symmetry breaking field as soon as the crystal has been localized in space at some time in the past. In general this may not be true, because the thermodynamic limit and the limit of the disappearing localization field do not commute. We should therefore also consider the situation in the presence of a small but finite symmetry breaking field B . In that case the energies of the system will be given by

$$E_m^n = n \sqrt{\frac{B}{2M(N+m)}} + \mu m, \quad (19)$$

which will again lead to a phase factor which is constant in n , and a sum over phases which can be written as multiples of $E_{thin} = \sqrt{B / 2M(N+m)}$ and $\Delta E_{thin} = E_{thin} / N$. The summation over thin spectrum states will thus again yield the coherence time $t_{spon} = N \frac{2\pi\hbar}{k_B T}$.

A. Goldstone modes

The interstitial excitation that is used in the previous section to make a qubit state out of the harmonic crystal is a

very rough excitation to use for that purpose. The extra atom in the crystal will not only increase the mass of the crystal as a whole but also immediately affect its lattice structure, and thus couple to many phonon excitations. Because of this, serious decoherence effects are to be expected. In constructing a qubit using the quantum crystal it is therefore better to look for a more “silent” excitation. These silent excitations are naturally found in the long wavelength Goldstone modes of the crystal, i.e., the low energy phonons.

To see what the effect of phonons on the thin spectrum is, we need to consider the symmetry breaking of the crystal more carefully. In the previous section we focused on the collective behavior of the crystal as a whole. Thus we disregarded all internal degrees of freedom. Now we are interested in the localization of the individual atoms within the crystal structure because the existence of the Goldstone phonons is a manifestation of the internal breaking of translational symmetry within the crystal lattice. For this purpose we introduce a symmetry breaking field V such that it acts as a pinning potential for the individual atoms:

$$H = H_0 + H_{SB} = \sum_j \frac{\mathbf{p}_j^2}{2m} + \frac{\kappa}{2} (\mathbf{x}_j - \mathbf{x}_{j+1})^2 - V \cos(2\pi \mathbf{x}_j). \quad (20)$$

Here the lattice constant a is taken as the unit of length. For small deviations of the atoms from their mean positions, we can expand the symmetry breaking term to read

$$\begin{aligned} H_{SB} &= V \sum_j 2\pi^2 \mathbf{x}_j^2 - \frac{2\pi^4}{3} \mathbf{x}_j^4 \\ &= 2V\pi^2 \sum_k \mathbf{x}_k \mathbf{x}_{-k} - \frac{2V\pi^4}{3N} \sum_{k,K,q} \mathbf{x}_k \mathbf{x}_K \mathbf{x}_q \mathbf{x}_{-k-K-q}, \end{aligned} \quad (21)$$

where the last line results from a Fourier transformation of the position operators. The thin spectrum of the crystal is formed by the zero momentum part of the Hamiltonian, while the phonons can be found after the bosonization and Bogoliubov transformation of the finite momentum part. The relation between the phonons and the thin spectrum thus becomes clear if we consider the zero momentum terms of H_{SB} in lowest order given by

$$H_{SB} \approx \frac{2V\pi^2}{N} \mathbf{x}_{tot}^2 - \frac{4V\pi^4}{N^2} \mathbf{x}_{tot}^2 \sum_{k \neq 0} \beta_k^\dagger \beta_k + \dots, \quad (22)$$

where higher order collective terms and boson-boson interaction terms are neglected. The first term in this expression is of the form of the symmetry breaking field that we considered before. It contains a factor $1/N$ because of the specific periodic pinning potential that we now consider. The symmetry of the crystal as a whole is still broken by this term, as can be easily checked by comparing the collective fluctuations to the size of the crystal. The energy scale of the thin spectrum is determined by the first term in (22) to be $E_{thin} \propto \frac{1}{N} \sqrt{\frac{B}{m}}$. The second term shows how the presence of a phonon excitation will in first order lead to an energy shift in the

thin spectrum which sets $\Delta E_{thin} \propto \frac{1}{N^2} \sqrt{\frac{B}{m}}$. Putting these together in the general expression for the decoherence time in Eq. (14), we immediately find once again that $t_{spn} \propto N \frac{\hbar}{k_B T}$.

III. LIEB-MATTIS MODEL

Let us now turn to the discussion of the antiferromagnetic Lieb-Mattis model. The reason for considering the rather particular, long ranged Lieb-Mattis model is that for a broad class of Heisenberg models with short-ranged interactions it constitutes the effective Hamiltonian for the thin states. Similar collective models underly the breaking of other continuous symmetries, such as for instance gauge symmetry in a superconductor. In that case the collective Hamiltonian turns out to be very similar to the Lieb-Mattis Hamiltonian as far as the structure of the thin spectrum and the composition of the wave function of the symmetry broken state are concerned. To explicitly show how the Lieb-Mattis model arises from a Heisenberg model, let us consider an antiferromagnet on a bipartite lattice with isotropic nearest neighbor interactions between quantum spins of size σ . Its Hamiltonian is

$$H = J \sum_{i,\delta} \mathbf{S}_i \mathbf{S}_{i+\delta}, \quad (23)$$

where i labels all the spins on the A sublattice, and the δ are the vectors connecting site i to its neighbors on sublattice B . The generalization to other types of interactions and even other types of lattices is straightforward.¹³⁻¹⁸ The magnon spectrum of this Hamiltonian can be found within linear spin wave theory. One approximates the spin operators with Holstein-Primakoff bosons as follows:

$$\begin{aligned} S_{i \in A}^z &\rightarrow \sigma - a_i^\dagger a_i, & S_{i \in B}^z &\rightarrow b_i^\dagger b_i - \sigma, \\ S_{i \in A}^+ &\rightarrow \sqrt{2\sigma} a_i, & S_{i \in B}^+ &\rightarrow \sqrt{2\sigma} b_i^\dagger, \\ S_{i \in A}^- &\rightarrow \sqrt{2\sigma} a_i^\dagger, & S_{i \in B}^- &\rightarrow \sqrt{2\sigma} b_i. \end{aligned} \quad (24)$$

To quadratic order in the boson operators the Hamiltonian becomes, after a Fourier transformation

$$\begin{aligned} H^{LSW} &= \frac{1}{2} J N z \sigma^2 + J z \sigma \sum_{\mathbf{k}} ((a_{\mathbf{k}}^\dagger a_{\mathbf{k}} + b_{\mathbf{k}}^\dagger b_{\mathbf{k}}) \\ &\quad + \gamma_{\mathbf{k}} (a_{\mathbf{k}}^\dagger b_{-\mathbf{k}}^\dagger + a_{\mathbf{k}} b_{-\mathbf{k}})), \end{aligned} \quad (25)$$

where z is the coordination number of the lattice, N the number of lattice sites and $\gamma_{\mathbf{k}} \equiv \frac{1}{z} \sum_{\delta} e^{i\mathbf{k} \cdot \delta}$. The last two terms in this expression can be diagonalized by a Bogoliubov transformation (see the Appendix). Again the important point is that the Bogoliubov transformation is singular at $k=0$ and $k=\pi$, as in both cases $\gamma_{\mathbf{k}}^2 \rightarrow 1$. We therefore treat these two k points separately. Turning back to the notation in terms of spins, using that the Fourier transform of our Hamiltonian is

$$H = J \sum_{\mathbf{k}} \gamma_{\mathbf{k}} \mathbf{S}_{\mathbf{k}} \cdot \mathbf{S}_{-\mathbf{k}} \quad (26)$$

and

$$\mathbf{S}_{\mathbf{k}=\mathbf{0}} = \frac{1}{\sqrt{N}} \sum_{i \in A, B} \mathbf{S}_i = \frac{1}{\sqrt{N}} (\mathbf{S}_A + \mathbf{S}_B),$$

$$\mathbf{S}_{\mathbf{k}=\pi} = \frac{1}{\sqrt{N}} (\mathbf{S}_A - \mathbf{S}_B)$$

we find that the singular parts of the spectrum reduce exactly to the Lieb-Mattis Hamiltonian

$$H = H_{LM}^{sym} + J \sum_{\mathbf{k} \neq 0, \pi} \gamma_{\mathbf{k}} \mathbf{S}_{\mathbf{k}} \cdot \mathbf{S}_{-\mathbf{k}},$$

$$H_{LM}^{sym} = \frac{2J}{N} \mathbf{S}_A \cdot \mathbf{S}_B = \frac{J}{N} (\mathbf{S}^2 - \mathbf{S}_A^2 - \mathbf{S}_B^2), \quad (27)$$

where \mathbf{S}_A and \mathbf{S}_B are the total spins of each sublattice, and \mathbf{S} is the *total* spin of the system. From here on we will focus entirely on this collective Hamiltonian, as it is the only part of the Heisenberg-like Hamiltonians that is relevant for the spontaneous symmetry breaking of the antiferromagnet as a whole. Notice that the *internal* ordering of the individual spins within the antiferromagnet can be destroyed by fluctuations of finite wavelength that we do not consider in this collective, long ranged model. We assign to the Hamiltonian H_{LM}^{sym} the superscript *sym* because this Hamiltonian, as we will show below, describes the symmetric (symmetry unbroken) state of the antiferromagnet.

In H_{LM}^{sym} each spin on the *A* sublattice interacts with all spins on the *B* sublattice and vice versa, thus creating infinite range interactions. The energies of the Hamiltonian are trivially identified as $\frac{J}{N} [S(S+1) - S_A(S_A+1) - S_B(S_B+1)]$ and the corresponding eigenfunctions are labeled by their quantum numbers $|S_A, S_B, S, M\rangle$. Here the *z* component of the total spin \mathbf{S} is denoted by M . Clearly the ground state of H_{LM}^{sym} is a singlet of total spin: the state with lowest energy has $S=0$. In fact there is an exact proof that the groundstate of any finite spin system of this sort is a total spin zero ($S=0$) singlet.¹⁹ Notice that all states which differ only in M are degenerate. For simplicity (and without loss of generality) we henceforth take the quantum number M to be zero.⁸

The groundstate singlet $|N\sigma/2, N\sigma/2, 0, 0\rangle$, with both S_A and S_B maximal and $S=M=0$ is separated by energies of order J/N from states with higher S . The set of these extremely low energy states that only differ in their total spin quantum number forms the thin spectrum.^{8,9,11} Since (27) is contained in (23) as its $\mathbf{k}=\mathbf{0}$ and $\mathbf{k}=\pi$ components, and since the thin spectrum of the Lieb-Mattis model is formed by the $\mathbf{k}=\mathbf{0}$ component, exactly the same thin spectrum must govern the collective dynamics of other antiferromagnets with short-range interactions.¹⁵⁻¹⁷

There are also excitations in (27) that can be created by lowering S_A or S_B . This costs an energy of order J , and it can easily be shown that these excitations correspond to the elementary excitations, the magnons, of the Lieb-Mattis system.²⁰ Because of the extremely long ranged interactions the magnons are gapped and dispersionless.

A. The Lieb-Mattis Hamiltonian with symmetry breaking field

Having defined the Lieb-Mattis model in its symmetric form, we now review how to explicitly break its $SU(2)$ spin rotation symmetry. We will show that in the thermodynamic limit the symmetry breaking occurs spontaneously.⁹ Since the groundstate of H_{LM}^{sym} is a singlet of total spin, this state is orthogonal to the Néel state, which is the ground state of a classical antiferromagnet. We should stress here that there is a marked difference between ferro- and antiferromagnets. Even if spontaneous symmetry breaking is very often discussed with the example of a ferromagnet at hand, the spontaneous symmetry breaking in a ferromagnet is not the generic situation for an interacting quantum system. The reason is that the total magnetization (pointing along, e.g., the *z* axis), which is the order parameter of a ferromagnet, commutes with the Hamiltonian: it is nothing but the projection of the total spin along that axis, S_{tot}^z . So the situation arises that the order parameter is a constant of motion, which is a pathology of the ferromagnet. This same pathology leads to the absence of an interesting thin spectrum, because in the ferromagnet states with different S_{tot}^z are strictly degenerate. Quantum systems in general, however, have nontrivial thin spectra.

Refocusing on antiferromagnets, we need to proof that the Néel state is a stable groundstate in the thermodynamic limit. In order to do so, an explicit symmetry breaking field B is introduced (Ref. 12).

$$H_{LM} = H_{LM}^{sym} - B(S_A^z - S_B^z). \quad (28)$$

Clearly the symmetry breaking field induces a finite sublattice magnetization. The field couples the different total spin states of the thin spectrum by the matrix elements

$$\begin{aligned} \langle S_A, S_B, S, M | S_A^z - S_B^z | S'_A, S'_B, S', M' \rangle \\ = \delta_{S_A, S'_A} \delta_{S_B, S'_B} \delta_{M, M'} [f_{S+1} \delta_{S, S'-1} + g_S \delta_{S, S'} + f_S \delta_{S, S'+1}], \end{aligned} \quad (29)$$

where

$$f_S \equiv \sqrt{\frac{[S^2 - (S_A - S_B)^2][(S_A + S_B + 1)^2 - S^2][S^2 - M^2]}{(2S+1)(2S-1)S^2}}$$

$$\text{and } g_S \equiv \frac{(S_A - S_B)(S_A + S_B + 1)M}{S(S+1)}. \quad (30)$$

These matrix elements are found by performing a rather tedious sum over Clebsch Gordon coefficients in the following expression (see also the Appendix):

$$\begin{aligned} \langle S_A, S_B, S, M | S_A^z - S_B^z | S'_A, S'_B, S', M' \rangle \\ = \sum_{M_A} [C_{S_A, S_B, M_A, M-M_A}^{S, M} C_{S_A, S_B, M_A, M-M_A}^{S', M} (2M_A - M)] \\ \times \delta_{S_A, S'_A} \delta_{S_B, S'_B} \delta_{M, M'}. \end{aligned} \quad (31)$$

The spectrum of eigenstates $|n\rangle$ in the presence of a symmetry breaking field can now be found by expanding these states in the basis of total spin states: $|n\rangle = \sum_S u_S^n |S\rangle$ (for clarity of notation we suppress the dependency of u_S^n and other vari-

ables on the quantum numbers S_A , S_B and M). In this basis, Schrödinger's equation becomes (Ref. 12)

$$H_{LM}|n\rangle = E_0^n|n\rangle \Leftrightarrow \sum_S \left[\frac{JS(S+1)}{N} u_S^n + E_{LM}^{sym} u_S^n - Bf_{S+1} u_{S+1}^n - Bf_S u_{S-1}^n \right] |S\rangle = E_0^n \sum_S u_S^n |S\rangle, \quad (32)$$

where E_{LM}^{sym} is the groundstate energy of H_{LM}^{sym} and E_0^n is the energy of eigenstate $|n\rangle$ of the symmetry broken Hamiltonian—its thin spectrum. Here we restricted ourselves to the zero-magnon subspace, where $S_A = S_B = N\sigma/2$ (hence the subscript 0 in E_0^n). The generalization to systems with a finite number of magnons will be straightforward.

In the continuum limit where N is large and $0 \ll S \ll N$, the matrix elements due to the symmetry breaking field simplify considerably. It is easy to show that in this case

$$f_S \approx \frac{N\sigma}{2} \sqrt{1 - \left(\frac{S}{N\sigma}\right)^2} \approx N\sigma/2. \quad (33)$$

We will see shortly that only the first $\approx \sqrt{N}$ total spin states contribute to the groundstate wave function, so that an expansion in S/N is justified. Notice that when the sublattice spin S_A is reduced by one, i.e., when there is a spin wave present, the matrix element f_S is reduced: $f_S^1 \approx f_S \frac{N\sigma-1}{N\sigma} = f_S \left(1 - \frac{1}{N\sigma}\right)$, for large N . This reflects the fact that a magnon reduces the Néel order parameter (the staggered magnetization) by unity. This effect is small, but turns out to be essential when we shall consider the quantum coherence of magnons: dephasing will occur because magnons give rise to a subtle change in the level splitting of the thin spectrum. This change in level splitting turns out to be inversely proportional to N , the total number of spins in the antiferromagnet.

In the continuum limit the Schrödinger's equation (32) reduces to (Ref. 12)

$$-\frac{1}{2} \frac{\partial^2}{\partial S^2} u_S^n + \frac{1}{2} \omega^2 S^2 u_S^n = \nu_n u_S^n, \quad (34)$$

where again we have used $0 \ll S \ll N$. In this equation we introduced $\omega = \frac{1}{N} \sqrt{\frac{2J}{B\sigma}}$ and $\nu_n = \frac{E_0^n - E_{LM}^0}{BN\sigma} + 1$. Obviously this is the differential equation of a harmonic oscillator. The eigenstates u_S^n thus are well known and the corresponding eigenvalues are $\nu_n = (n+1/2)\omega$, so that

$$E_0^n = E_{LM}^{sym} - BN\sigma + \left(n + \frac{1}{2}\right) E_{thin}, \quad (35)$$

where the quantum of energy for the states labeled by n is $E_{thin} = \sqrt{2\sigma JB}$. For the harmonic oscillator n is a nonnegative integer. However, in the present situation we have to meet the boundary condition that $S \geq 0$ or, equivalently, that $u_S^n = 0$ if $S < 0$. So u_S^n has to vanish at the origin. This boundary condition is trivially met by eigenfunctions that are odd and have a node at $S=0$, see Fig. 1. Thus solutions to the Schrödinger's equation (34) are harmonic oscillator eigenfunctions of order n , where n is an odd positive integer. In Fig. 2 the groundstate wave function in the continuum limit

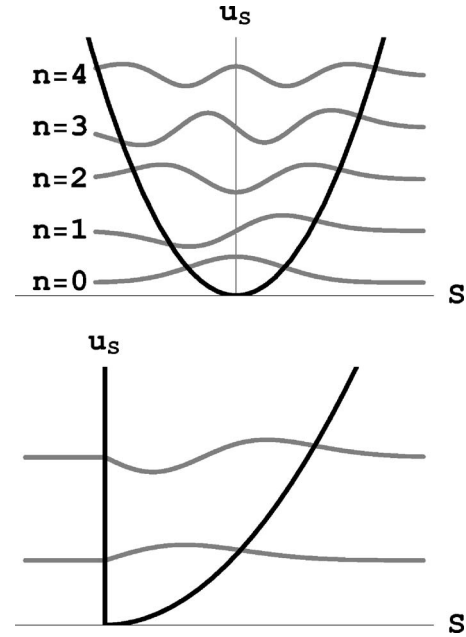

FIG. 1. Wave functions of the thin-spectrum state in presence of a symmetry breaking field, in the continuum limit. The boundary condition $S \geq 0$ implies that of the harmonic oscillator solutions (left) only the odd ones are allowed (right), as these have a node at the origin.

is compared with the exact wave function for large N . It makes clear that the continuum approximation is very good one.

Let us consider the energy spectrum in Eq. (35) in more detail. Clearly if B is zero we recover the groundstate energy

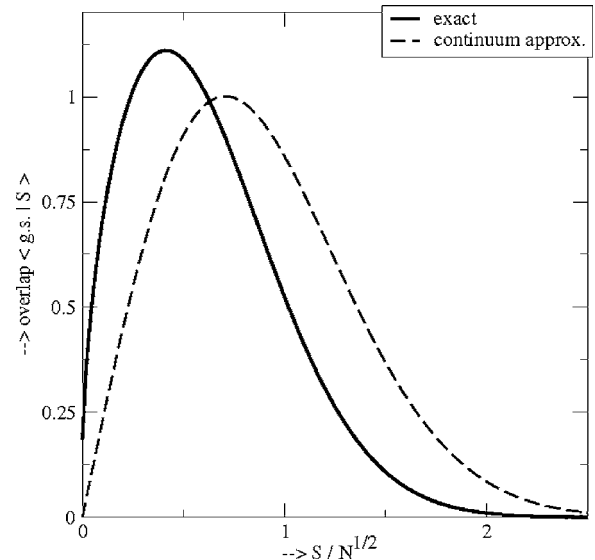

FIG. 2. Comparison of the exact symmetry broken Néel wave function (for $N=500$ spins) and the Néel wave function in the continuum limit (a harmonic oscillator eigenstate). The overlap of the Néel state with the different total spin states is shown as a function of the total spin quantum number. The parameters are $J=1$ and the symmetry breaking field is $B=1/10$. The wave functions are rescaled such that the maximum of the harmonic oscillator wave function is unity.

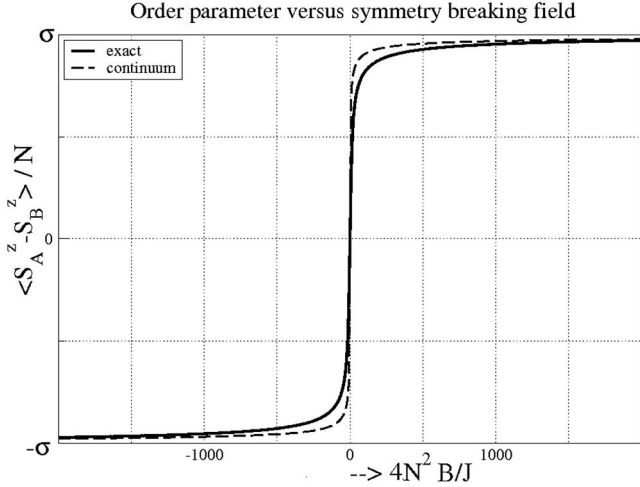

FIG. 3. Order parameter as a function of symmetry breaking field. The exact result for $N=100$ spins, the continuum expression for the order parameter is derived in the Appendix.

E_{LM}^{sym} of the symmetric case that we discussed before. However, if there is a finite staggered field B , there is a gain in groundstate energy proportional to BN , which reveals that the energy spectrum in Eq. (35) is the one of a Néel state. The same conclusion is reached by directly calculating the order parameter (see the Appendix). The result is shown in Fig. 3. Apparently, for the symmetry broken Néel state to be stable, the symmetry breaking field can be exceedingly small, as long as N is large enough. In other words: in the thermodynamic limit the spin rotation symmetry of H_{LM}^{sym} can be *spontaneously* broken by an infinitesimal field B . Putting it in a more formal manner: spontaneous symmetry breaking gives rise to the singular limit

$$\begin{aligned} \lim_{N \rightarrow \infty} \lim_{B \rightarrow 0} \left\langle \frac{S_A^z - S_B^z}{N\sigma} \right\rangle &= 0 \text{ and} \\ \lim_{B \downarrow 0} \lim_{N \rightarrow \infty} \left\langle \frac{S_A^z - S_B^z}{N\sigma} \right\rangle &= 1. \end{aligned} \quad (36)$$

This in fact defines spontaneous symmetry breaking, just as it did in the case of the quantum crystal. That for the Lieb-Mattis Hamiltonian this limit is singular is directly clear from Fig. 3.

In the symmetry broken Néel state, the excitations labeled by n now act as the thin spectrum, with excitation energies that are multiples of $E_{thin} = \sqrt{2}\sigma JB$. The magnon excitation energy is still of order J .

We now repeat the analysis above for a Néel state with m magnons (by setting $S_A = S_B = N\sigma/2 - m/2$ and using f_S^m instead of f_S). In this case the energy spectrum becomes

$$E_m^n = E_0^n + m(2\sigma J + B) - \frac{m}{2N\sigma}(n + 1/2)E_{thin}, \quad (37)$$

see Fig. 4. Note that as we stated before, there is a subtle effect of the magnons on the thin states: m magnons cause a change in energy of the thin spectrum of the order of m/N . This effect will turn out to be essential for the decoherence

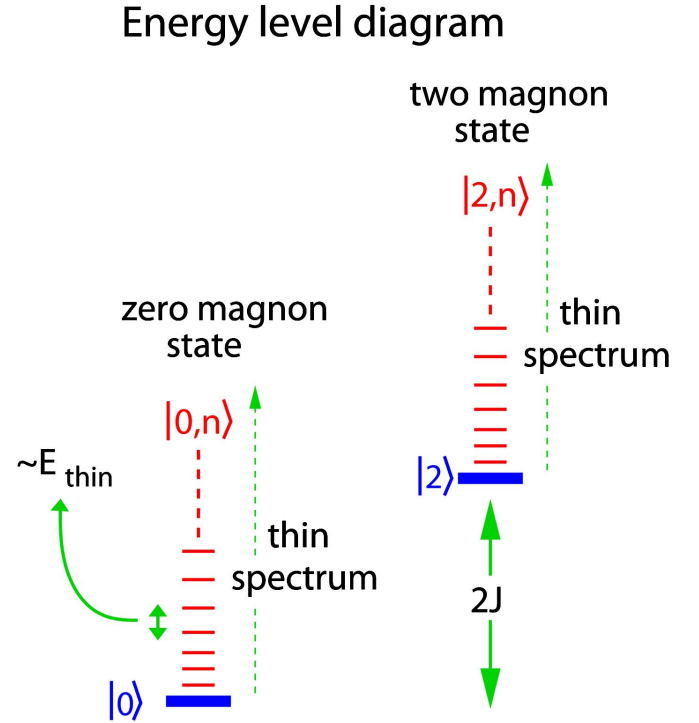

FIG. 4. (Color online) Energy level scheme with the zero and two magnon states, each with its tower of thin spectrum states. The level spacing in the thin spectrum is E_{thin} , magnons live on an energy scale J .

mechanism that we will discuss in the following section.

Physically the change in energy of the thin states due to the presence of a magnon can easily be understood. If there are m magnons present in the antiferromagnet, then the order parameter of the total system is reduced by m . Since the thin spectrum describes the global excitations of the order parameter, its energy is proportional to the order parameter itself. The ratio of the Néel order parameter of the excited state with m magnons and the one of the groundstate with a fully developed order parameter is $(N-m)/N$. Therefore, when there are m magnons present, the relative change of the order parameter is m/N and the change in energy of the thin states is therefore of the order mE_{thin}/N which explains the last term in expression (38).

B. Preparing the many-spin qubit

Using the many-body Lieb-Mattis model with N spins and $\sigma=1/2$, we now study the coherence of the antiferromagnet when it is used as a qubit. Again there are many ways in which one can define a two-level system to be used as the qubit states. The best possible choice in this case is provided by the gapped and dispersionless magnons: we use as a qubit (or cat state) the superposition of a perfectly ordered antiferromagnet and the state of the antiferromagnet with one magnon on each sublattice. Due to the long-range nature of the interaction in the Lieb-Mattis model the gapped magnons themselves are not damped and as such do not decay or decohere. Also, in analogy to the quantum crystal we expect the magnons or Goldstone modes of the antiferromagnet to

influence the thin spectrum as little as possible. A magnon has an energy J , which we assume is the energy scale that is available to the (thought-)experimentalist to prepare, manipulate, and read out the qubit.²²

With the exact expressions for all eigenstates and energies of both the symmetric and the symmetry broken Hamiltonian at hand, we are in the position to set up the initial state for our many-particle qubit. Instead of simply assuming that we are in a previously prepared superposition of states with zero and two magnons, we will explicitly construct this initial state. This can be done by coupling at time $t=t_0$ a two spin singlet to the symmetry broken N -spin Lieb-Mattis system, see Fig. 5. From this the desired superposition results. So for times $t < t_0$, the Lieb-Mattis antiferromagnet is completely decoupled from the two spin singlet and the total wave function is thus the direct product of the wave functions of the N -spin magnet and the two-spin singlet state:

$$|\psi_{t < t_0}\rangle = |0, n\rangle \otimes |\text{singlet}\rangle. \quad (38)$$

Here we denote the Néel state with m magnons and n thin spectrum excitations by $|m, n\rangle$. The state $|\text{singlet}\rangle$ is $\frac{1}{\sqrt{2}}[|\downarrow_1\uparrow_2\rangle - |\uparrow_1\downarrow_2\rangle]$. Upon instantaneous inclusion at $t=t_0$ of the two spin state in the Lieb-Mattis lattice, the groundstate of the decoupled system at $t < t_0$ can be expressed in terms of the eigenstates of the $N+2$ spin system at $t=t_0$. The exact groundstate wave function is then given by the following formidable expression:

$$\begin{aligned} |\psi_{t < t_0}\rangle = & \sum_{S=0}^{N-1} u_S^n \left(\sqrt{\frac{(N-2+2S)(N+4+2S)}{2(N+2)^2}} \left| \frac{N+2}{4}, \frac{N+2}{4}, S, 0 \right\rangle + \sqrt{\frac{2S(S+1)}{(N+2)^2}} \left| \frac{N+2}{4}, \frac{N-2}{4}, S, 0 \right\rangle \right. \\ & \left. - \sqrt{\frac{2S(S+1)}{(N+2)^2}} \left| \frac{N-2}{4}, \frac{N+2}{4}, S, 0 \right\rangle + \sqrt{\frac{(N-2S)(N+2+2S)}{2(N+2)^2}} \left| \frac{N-2}{4}, \frac{N-2}{4}, S, 0 \right\rangle \right). \end{aligned} \quad (40)$$

Again the equations simplify drastically in the continuum limit of large N , where as before $0 \ll S \ll N$. In this case the wave function of the system at $t < t_0$, expressed in the eigenstates of the $N+2$ spin system at $t=t_0$ is

$$|\psi_{t < t_0}\rangle = [|0, n\rangle + |2, n\rangle]/\sqrt{2}. \quad (41)$$

Here all states on the right-hand side, i.e., all the thin spectrum states labeled by their quantum number n with either zero or two magnons, refer to configurations of $N+2$ spins.

To account for a finite temperature of our many particle qubit, we combine initial states with different n into a thermal mixture before we let it interact with the two spin singlet. We should stress that we only consider temperatures

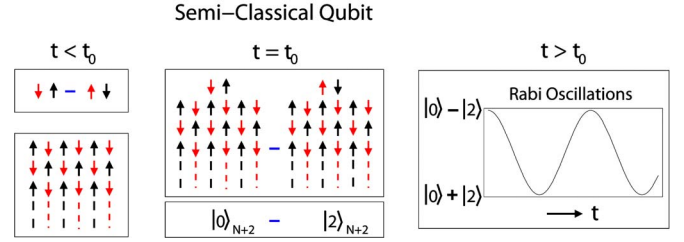

FIG. 5. (Color online) Semiclassical time evolution of a two spin qubit that at $t=t_0$ starts interacting with a N -spin Lieb-Mattis magnet, thus forming at $t > t_0$ a many-body qubit made out of $N+2$ spin. Quantum coherence is preserved at all times, since in this semiclassical approximation the thin spectrum is neglected.

$$\begin{aligned} |\psi_{t < t_0}\rangle = & \sum_{S=0}^{N-1} u_S^n |S, 0\rangle \otimes |\text{singlet}\rangle \\ = & \sum_{S=0}^{N-1} u_S^n \sum C_{N/4, N/4, M_A, -M_A}^{S, 0} C_{1/2, 1/2, M_1, -M_1}^{0, 0} C_{N/4, 1/2, M_A, M_1}^{S_{A1}, M_A + M_1} \\ & \times C_{N/4, 1/2, -M_A, -M_1}^{S_{B2}, -M_A - M_1} C_{S_{A1}, S_{B2}, M_A + M_1, -M_A - M_1}^{S, 0} \\ & \times \delta_{S, S'} |S_{A1}, S_{B2}, S, 0\rangle, \end{aligned} \quad (39)$$

where we sum the Clebsch-Gordon coefficients over M_A , M_1 and over the total spins S_{A1} , S_{B2} , and S , A/B denote the spins on sublattices A and B and the spins on sites 1 and 2 make up the singlet. With A1(B2) we denote the set of spins on sublattice A(B) combined with spin 1(2). The sums can be evaluated and we obtain

that are much below the magnon energy: $k_B T \ll J$ so that there is no thermal occupation of the magnon states.²³ This implies that the order parameter is not affected by the thermal fluctuations. So, all that we introduce is an incoherent mixture of the low lying thin spectrum states, which all support a finite sublattice magnetization. Still, the implicit assumption is that the thin states are in thermal equilibrium—and it is an important assumption as our final result relies on it. In principle it can of course not be excluded that occupation distribution of the thin spectrum states is far from thermal equilibrium. But as we have not *a priori* prepared the thin states in some particular way, we assume them to be thermally occupied. Then the density matrix at times $t < t_0$ is then

$$\begin{aligned}
\rho_{t < t_0} &= \frac{1}{Z} \sum_n e^{-\beta E_0^n} |0, n\rangle \otimes |singlet\rangle \langle singlet| \otimes \langle 0, n| \\
&= \frac{1}{2Z} \sum_n e^{-\beta E_0^n} (|0, n\rangle \langle 0, n| + |0, n\rangle \langle 2, n| \\
&\quad + |2, n\rangle \langle 0, n| + |2, n\rangle \langle 2, n|), \tag{42}
\end{aligned}$$

where, by definition, the partition function is $Z = \sum_n e^{-\beta E_0^n}$ and $\beta^{-1} = k_B T$.

IV. TIME EVOLUTION AND DECOHERENCE

By coupling the symmetry broken Lieb-Mattis model to the two spin singlet, we have created the initial state of our $N+2$ spin qubit. This initial state is precisely equivalent to the initial state (9) of the general description, and we can thus follow Eqs. (10)–(12) directly. That way we compute the *exact* time evolution of the initial state density matrix, trace away the thin spectrum states which have vanishing thermodynamic weight, and finally define the off-diagonal element of the reduced density matrix as follows:

$$\rho_{t > t_0}^{OD} \equiv \frac{1}{Z} \sum_n e^{-\beta E_0^n} e^{-i(E_0^n - E_2^n)(t-t_0)/\hbar}. \tag{43}$$

We can then substitute the exact expressions for E_n^m in this matrix element, and perform the summation. We find

$$\rho_{t > t_0}^{OD} = \frac{1 - e^{-x}}{1 - e^{-Nx}} \frac{1 - e^{-N(x+i\tau)}}{1 - e^{-x-i\tau}}, \tag{44}$$

where $x = \frac{E_{thin}}{k_B T}$ and $\tau = \frac{2}{\hbar} \Delta E_{thin} (t - t_0)$, with $E_{thin} = \sqrt{JB}$ and $\Delta E_{thin} = E_{thin}/N$ (see Fig. 6). We again define the coherence time t_{spon} as the half-time of $|\rho_{t > t_0}^{OD}|$. For $x, \tau \ll 1$, expression (44) becomes a Lorentzian, and in that limit one thus finds

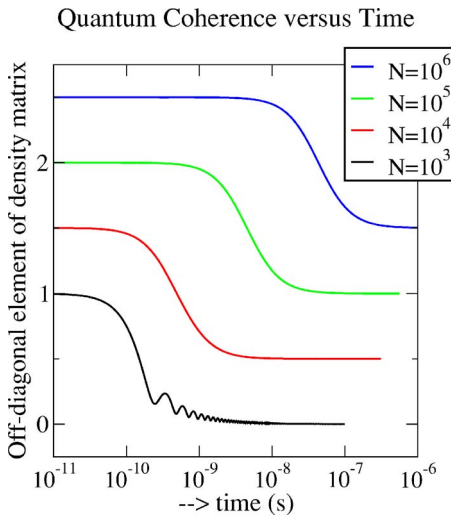

FIG. 6. (Color online) The time dependence of the entanglement between states $|0\rangle$ and $|2\rangle$, $|\rho_t^{OD}|$, for different number of spins N at $T=10$ K and $t_{rec}/t_{dec}=10^3$. For clarity curves for different N have an offset of $1/2$.

$$t_{spon} \simeq \frac{2\pi N \hbar}{k_B T}, \tag{45}$$

our main result.

Notice that just as in the case of using a quantum crystal with an interstitial excitation, the coherence time t_{spon} in the end does not depend on any details of the underlying model. The fact that ΔE_{thin} is proportional to E_{thin} itself removes all dependence of t_{spon} on the model parameters J and B .

A. Physical interpretation

It is remarkable that the coherence time is such a universal time scale, independent of the detailed form of the thin spectrum—which, after all, is determined by the parameters J and B in the Lieb-Mattis Hamiltonian. Mathematically this is due to the fact that both x and τ are proportional to E_{thin} . Physically one can think of this universal time scale as arising from two separate ingredients. First, the energy of a thin spectrum state $|n\rangle$ changes when magnons appear, as we pointed out above. The change is of the order of nE_{thin}/N , where E_{thin} is the characteristic level spacing of the thin spectrum that we happen to be considering. The fact that each thin state shifts its energy somewhat at $t > t_0$ leads to a phase shift of each thin state and in general these phases interfere destructively, leading to dephasing and decoherence. The larger nE_{thin}/N , the faster this dynamics.

But from the argument above it is clear that in order for this dephasing to occur, it is necessary for a finite number of thin states to participate in the dynamics of decoherence. Since temperature is finite (but always small compared to the magnon energy) a finite part of the thin spectrum is available for the dynamics. Thin spectrum states with an excitation energy higher than $k_B T$ are suppressed exponentially due to their Boltzmann weights. Therefore the maximum number of thin states that do contribute is roughly determined by the condition that $n^{max} \sim k_B T / E_{thin}$. Putting the ingredients together, we find that the highest energy scale that is available to the system to decohere is approximately $n^{max} E_{thin} / N = \frac{k_B T E_{thin}}{E_{thin} N}$. All together, the thin spectrum drops out of the equations. The time scale at which the dynamics take place is determined by the inverse of this energy scale, converted into time. From this argument we immediately find again the coherence time $t_{spon} \sim \frac{2\pi \hbar N}{k_B T}$.

This physical picture also suggests an alternative way of introducing decoherence into the many particle qubit. Instead of raising the temperature and making an incoherent superposition of more and more thin spectrum states, we could start out at $t < t_0$ with the Lieb-Mattis antiferromagnet in its (zero temperature) symmetric ground state, and then instantaneously turn on the symmetry breaking field B at $t = t_0$. At $t > t_0$ the eigenstates are the Néel-like thin spectrum states $|n\rangle$. No magnons are created by switching on the symmetry breaking field. As we can expand the states $|n\rangle$ in the basis of total spin states as $|n\rangle = \sum_S u_S^n |S\rangle$ we can, by the inverse transformation, expand the total spin singlet state in the basis of the Néel-like thin spectrum states as $|S=0\rangle = \sum_n u_n^0 |n\rangle$. We can now use this singlet state as the initial state for our qubit. This singlet state is a superposition of all of the different

Néel-like states, which are separated by energies E_{thin} . This procedure thus roughly corresponds to creating a “maximal temperature” $k_B T \sim N E_{thin}$. When time evolves all of these states pick up different phases, which leads to decoherence when we trace over them. The coherence time due to this switching on of the symmetry breaking field is therefore $t_{SB} = \frac{2\pi\hbar}{\sqrt{J}B}$.

B. Symmetric case and short-ranged models

This raises the question what would have happened if we had *not* broken the symmetry in the Lieb-Mattis magnet (by introducing a finite symmetry breaking field B) at all. In the symmetric case S , S_A , and S_B are good quantum numbers at all times. It is easy to see that in this situation the thin spectrum, determined by the quantum number S , is independent of the “magnon” states, which are determined by the quantum numbers S_A and S_B . Since in the symmetric Lieb-Mattis Hamiltonian the thin spectrum does not communicate with the magnons and vice versa, we will find $\Delta E_{thin} = 0$, and accordingly no decoherence.

The fact that S , S_A , and S_B are all good quantum numbers, may be regarded as a pathology of the Lieb-Mattis model. In fact, the model is integrable just because there are so many conserved quantities. In a more general, short-ranged Heisenberg model the magnons will acquire a finite lifetime and it is expected that they will in general influence the structure of the thin spectrum, even if the symmetry breaking field is absent. In this sense, the Lieb-Mattis model can really be seen as the best case scenario for avoiding decoherence in SU(2) symmetric models. Its infinitely long ranged interactions introduce a large energy gap for all magnons, which thus become extremely silent excitations. On top of that the coupling to the collective dynamics is so subtle that it can only be seen because of the existence of a singular limit: Only because we need to always consider an infinitesimal symmetry breaking field when looking at the thermodynamic limit do we find decoherence at all.

C. Recurrence

Finally we notice that the off-diagonal elements of the density matrix, Eq. (44), are periodic in time, and the initial density matrix recurs when $N\tau = 2\pi$ or, equivalently, $t_{rec} = \pi\hbar / E_{thin}$. Such a periodicity is required by the fact that the time evolution is unitary. As the recurrence time is inversely proportional to the level spacing of the thin spectrum, it depends on the microscopic parameters of the model. It becomes infinitely long if the symmetry breaking field vanishes. In the physical limit the recurrence time is always much longer than the decoherence time as $t_{rec}/t_{spon} = k_B T / E_{thin} \gg 1$.

V. CONCLUSIONS

A many-body qubit has an intrinsic limit to its maximum coherence time. In this paper we have presented in detail the considerations and calculations that lead to this conclusion.

The limit to coherence is caused by the thin spectrum. In quantum systems a continuous symmetry can spontaneously

be broken in the thermodynamic limit due to these states. The thin modes can be identified with the collective, zero momentum, excitations of the order parameter. In this paper we have outlined a general procedure for finding the thin spectrum states in a quantum systems. The states within the thin spectrum are extremely low in energy and at the same time they are so few that their contribution to the thermodynamic partition function vanishes.

If a symmetry breaking field is introduced, the resulting symmetry broken ground state is a superposition of (only) these thin spectrum states. The fact that the formation of the symmetry broken state occurs spontaneously in the thermodynamic limit can then easily be checked by considering the noncommuting limits of disappearing field and sending the number of involved particles to infinity.

This has important consequences when a many-body quantum system is brought into a superposition of two different internal states. We have shown that in that case the thin states will in general participate in the time evolution of the full many-body system, even if their effect on any thermodynamic quantity vanishes. This leads to dephasing and therefore decoherence when the thin states are integrated out. We have found that the time scale corresponding to the dephasing process depends only on the energy scale of the thin spectrum and the energy shifts induced in the thin spectrum by the superposed initial states. Because the shifts in energy generally are proportional to the level spacing itself, the decoherence time in the end depends only on the temperature and size of the system, and not on the underlying details of the model.

We have shown how such superpositions can be defined and studied in a quantum crystal and in the Lieb-Mattis antiferromagnet. The obvious question is to what extent the Lieb-Mattis qubit is representative of a general many-body qubit. In fact the Lieb-Mattis qubit is the best case scenario for the kind of many-body qubits envisaged in main stream quantum information theory, as its behavior is extremely close to semiclassical due to the presence of the infinite range interactions. Qubits characterized by short range interactions carry massless Goldstone modes and these will surely act as an additional heat bath limiting the coherence time. It is of course not an accident that the most “silent” systems are qubits based on superconducting circuitry, which have a massive excitation spectrum in common with the Lieb-Mattis system. We have demonstrated here that even under these most favorable circumstances quantum coherence eventually has to come to an end, because of the unavoidable condition that even the most silent qubits are subtly influenced by their quantum origin. These effects become noticeable in the mesoscopic realm and we present it as a challenge to the experimental community to measure the maximum coherence time that they give rise to: $t_{spon} \sim \frac{2\pi\hbar N}{k_B T}$.

ACKNOWLEDGMENTS

We thank Mikhail Katsnelson and Philip Stamp for fruitful discussions. This work was supported by FOM and the Dutch Science Foundation.

APPENDIX

1. Thermodynamic weight of thin spectrum states

It is easy to show that the contribution of the thin spectrum of the symmetric N -spin Lieb-Mattis Hamiltonian to the

free energy density is proportional to $\frac{\ln N}{N}$ and thus vanishing in the thermodynamic limit. The energy of a state with total spin S is $E_{thin} = J/NS(S+1)$ and its degeneracy is $2S+1$, so that the contribution of the thin states to the partition function is

$$Z_{thin} = \sum_{S=0}^N (2S+1)e^{-\beta E_{thin}} \approx \int_0^N (2S+1)e^{-\beta J/NS(S+1)} dS \approx \frac{N}{\beta J}, \quad (\text{A1})$$

in the limit of large N . Therefore its total contribution to the free energy is $F_{thin} = -T \ln Z_{thin} \propto -\ln N$ and for large N its contribution to the free energy per spin—and the free energy density—is proportional to $\frac{\ln N}{N}$.

2. Matrix elements

By expressing the matrix elements of all components of the spin operators \mathbf{S}_A and \mathbf{S}_B in terms of Clebsch-Gordon coefficients, one can evaluate them by performing the appropriate summations. The resulting matrix elements are:

$$\begin{aligned} \left\langle S'_A S'_B S' M' \left| S_A^\pm | S_A S_B S M \right. \right\rangle = & \left[\mp \delta_{S', S+1} \sqrt{\frac{[S'^2 - (S_A - S_B)^2][(S_A + S_B + 1)^2 - S'^2](S' \pm M)(S' \pm M + 1)}{4(4S'^2 - 1)S'^2}} \right. \\ & + \delta_{S', S} \frac{[(S_A - S_B)(S_A + S_B + 1) + S(S + 1)]\sqrt{(S \pm M + 1)(S \mp M)}}{2S(S + 1)} \\ & \left. \pm \delta_{S', S-1} \sqrt{\frac{[S^2 - (S_A - S_B)^2][(S_A + S_B + 1)^2 - S^2](S \mp M)(S \mp M - 1)}{4(4S^2 - 1)S^2}} \right] \delta_{S'_A, S_A} \delta_{S'_B, S_B} \delta_{M', M \pm 1} \end{aligned} \quad (\text{A2})$$

$$\begin{aligned} \left\langle S'_A S'_B S' M' \left| S_A^\pm | S_A S_B S M \right. \right\rangle = & \left[\delta_{S', S+1} \sqrt{\frac{[S'^2 - (S_A - S_B)^2][(S_A + S_B + 1)^2 - S'^2](S'^2 - M^2)}{4(4S'^2 - 1)S'^2}} \right. \\ & + \delta_{S', S} \frac{[(S_A - S_B)(S_A + S_B + 1) + S(S + 1)]M}{2S(S + 1)} \\ & \left. + \delta_{S', S-1} \sqrt{\frac{[S^2 - (S_A - S_B)^2][(S_A + S_B + 1)^2 - S^2](S^2 - M^2)}{4(4S^2 - 1)S^2}} \right] \delta_{S'_A, S_A} \delta_{S'_B, S_B} \delta_{M', M}, \end{aligned} \quad (\text{A3})$$

$$\langle S'_A S'_B S' M' | S_B^\pm | S_A S_B S M \rangle = -\langle S'_A S'_B S' M' | S_A^\pm | S_A S_B S M \rangle + \delta_{S', S} \sqrt{(S \pm M + 1)(S \mp M)}, \quad (\text{A4})$$

$$\langle S'_A S'_B S' M' | S_B^\pm | S_A S_B S M \rangle = -\langle S'_A S'_B S' M' | S_A^\pm | S_A S_B S M \rangle + M \delta_{S', S}. \quad (\text{A5})$$

3. The Bogoliubov transformation

We have used a Bogoliubov transformation to diagonalize bosonic bilinear Hamiltonians of the form

$$H = \sum_k A_k b_k^\dagger b_k + \frac{B_k}{2} (b_k b_{-k} + b_k^\dagger b_{-k}^\dagger), \quad (\text{A6})$$

where $A_{-k} = A_k$ and $B_{-k} = B_k$. The relevant transformed bosons β_k^\dagger are defined through

$$b_k^\dagger = \cosh(u_k) \beta_{-k}^\dagger - \sinh(u_k) \beta_k,$$

$$b_{-k} = \cosh(u_k) \beta_k - \sinh(u_k) \beta_{-k}^\dagger. \quad (\text{A7})$$

The parameters u_k obey $u_k = u_{-k}$ and are chosen such that the Hamiltonian reduces to diagonal form. This implies that

$$\cosh(2u_k) = \frac{A_k}{\sqrt{A_k^2 - B_k^2}},$$

$$\sinh(2u_k) = \frac{B_k}{\sqrt{A_k^2 - B_k^2}} \text{ and}$$

$$H = \sum_k \sqrt{A_k^2 - B_k^2} \left(\beta_k^\dagger \beta_k + \frac{1}{2} \right) - \frac{1}{2} A_k. \quad (\text{A8})$$

We can also use the exact same definition of u_k to diagonalize the Hamiltonian

$$H = \sum_k A_k (a_k^\dagger a_k + b_k^\dagger b_k) + B_k (a_k b_{-k} + a_k^\dagger b_{-k}^\dagger). \quad (\text{A9})$$

In that case the transformed bosons and Hamiltonian are given by

$$a_k^\dagger = \cosh(u_k) \beta_{-k}^\dagger - \sinh(u_k) \alpha_k,$$

$$b_k^\dagger = \cosh(u_k) \alpha_{-k}^\dagger - \sinh(u_k) \beta_k \text{ and}$$

$$H = \sum_k \sqrt{A_k^2 - B_k^2} (\alpha_k^\dagger \alpha_k + \beta_k^\dagger \beta_k + 1) - A_k. \quad (\text{A10})$$

4. The order parameter

Consider the symmetry broken Lieb-Mattis Hamiltonian:

$$H = \frac{2J}{N} \mathbf{S}_A \cdot \mathbf{S}_B - B (S_A^z - S_B^z). \quad (\text{A11})$$

If the number of spins N is large, then the eigenfunctions $|n\rangle$ of this Hamiltonian are to a very good approximation given by the eigenfunctions of (half of) a harmonic oscillator:

$$|n\rangle = \sum_S u_S^n |S\rangle = \sum_S \sqrt{\frac{\sqrt{\omega}}{\sqrt{\pi} 2^{n-1} n!}} e^{-1/2 \omega S^2} H_n(\sqrt{\omega} S) |S\rangle, \quad (\text{A12})$$

where $|S\rangle$ are the total spin eigenstates, H_n are the Hermite polynomials, ω equals $\frac{2}{N} \sqrt{\frac{J}{B}}$, and n can only be an odd integer number. Using this exact expression to calculate the ground state expectation value of the order parameter, we find:

$$\begin{aligned} \langle S_A^z - S_B^z \rangle &= \sum_{S, S'} u_S^1 u_{S'}^1 \langle S' | S_A^z - S_B^z | S \rangle \\ &= 2 \sum_S u_S^1 u_{S-1}^1 \sqrt{\frac{((N/2 + 1)^2 - S^2) S^2}{4S^2 - 1}}. \end{aligned} \quad (\text{A13})$$

The shape of the function u_S^1 guarantees that $S \ll N$, so that for large N the expectation value is approximately given by:

$$\begin{aligned} &\frac{N}{2} \int_1^\infty \sqrt{\frac{16}{\pi}} \omega^{3/2} S e^{-(1/2) \omega S^2} (S-1) e^{-(1/2) \omega (S-1)^2} dS \\ &= \frac{N}{2} \left[e^{-(1/4) \omega} \left(1 - \frac{1}{2} \omega \right) \left(1 - \operatorname{erf} \left(\sqrt{\frac{\omega}{4}} \right) \right) + \sqrt{\frac{\omega}{4}} e^{-(1/2) \omega} \right] \\ &= \frac{N}{2} e^{-\sqrt{(J)/(B)} (1)/(2N)} + O(1), \end{aligned} \quad (\text{A14})$$

which reduces to the classically expected order parameter in the thermodynamic limit. Note that in this expression it is immediately clear that the limit of vanishing symmetry breaking field does not commute with the limit of infinitely many spins: they form a singular limit.

5. Relation to the quantum measurement process

Having seen the interaction between the Lieb-Mattis antiferromagnet and a two spin singlet, and the subsequent decoherence, one could be tempted to claim that what we have here is a description of a quantum measurement process. Indeed we started out with a macroscopic, symmetry broken, classical state (the antiferromagnet) and coupled it to a microscopic spin state. The classical mixed state that we end up with at times $t|_{\text{spn}}$ seemed to consist only of states with either zero or two magnons, since the off-diagonal matrix elements which mix the two states had disappeared. It should be noted however, that this is *not* enough to constitute a description of quantum measurement. If we consider the coupling of a single two spin singlet to the antiferromagnet the calculations imply that the resulting state is a macroscopic superposition of zero and two magnon states, which in fact remains coherent forever. The apparent reduction to a classical mixture of states is due to the fact that we choose to trace away a certain portion of the available Hilbert space (i.e., the thin spectrum). This leads to decoherence. If we were to wait long enough, the unitarity of quantum mechanical time evolution guarantees that after a time t_{rec} the original quantum superposition of zero and two magnons shows up again. Since t_{rec} turns out to be a very long time, one could be tempted to make the case that for all practical purposes our description gives the same result as a true measurement process would give. This is not so. It should always be kept in mind that *decoherence* of states, as we have here, is very different from a *projection* of states.²¹ Projections are non-unitary. A single quantum measurement is a projection of the wave function. The statistical interpretation of quantum mechanics of course circumvents this problem: *ensembles* of our decohered states and *ensembles* of measured states have exactly the same density matrix. However, if one aims to describe a single measurement then decoherence cannot explain the projection of states that apparently takes place experimentally.

¹J. van Wezel, J. van den Brink, and J. Zaanen, Phys. Rev. Lett. **94**, 230401 (2005).

²I. Chiorescu, Y. Nakamura, C. J. P. M. Harmans, and J. E. Mooij, Science **299**, 1869 (2003).

³C. H. van der Wal, A. C. J. ter Haar, F. K. Wilhelm, R. N. Schouten, C. P. M. Harmans, T. P. Orlando, S. Lloyd, and J. E. Mooij, Science **290**, 773 (2000).

⁴Y. Nakamura, Yu. A. Pashkin, and J. S. Tsai, Nature (London)

- 398**, 786 (1999); Y. Nakamura, Yu. A. Pashkin, T. Yamamoto, and J. S. Tsai, Phys. Rev. Lett. **88**, 047901 (2002).
- ⁵D. Vion, A. Aassime, A. Cottet, P. Joyez, H. Pothier, C. Urbina, D. Esteve, and M. H. Devoret, Science **296**, 886 (2002).
- ⁶J. R. Friedman, M. P. Sarachik, J. Tejada, and R. Ziolo, Phys. Rev. Lett. **76**, 3830 (1996).
- ⁷D. D. Awschalom, J. F. Smyth, G. Grinstein, D. P. DiVincenzo, and D. Loss, Phys. Rev. Lett. **68**, 3092 (1992).
- ⁸E. Lieb and D. Mattis, J. Math. Phys. **3**, 749 (1962).
- ⁹P. W. Anderson, Phys. Rev. **86**, 694 (1952); P. W. Anderson, Science **177**, 393 (1972).
- ¹⁰See, for instance, S. Coleman, *Aspects of Symmetry* (Cambridge University Press, Cambridge, 1985), Chap. 5.
- ¹¹T. A. Kaplan, W. von der Linden, and P. Horsch, Phys. Rev. B **42**, 4663 (1990).
- ¹²C. Kaiser and I. Peschel, J. Phys. A **22**, 4257 (1989).
- ¹³B. Bernu, P. Lecheminant, C. Lhuillier, and L. Pierre, Phys. Rev. B **50**, 10048 (1994).
- ¹⁴L. Capriotti, Int. J. Mod. Phys. B **15**, 1799 (2001).
- ¹⁵B. Bernu, C. Lhuillier, and L. Pierre, Phys. Rev. Lett. **69**, 2590 (1992).
- ¹⁶H. Neuberger and T. Ziman, Phys. Rev. B **39**, 2608 (1989).
- ¹⁷D. S. Fisher, Phys. Rev. B **39**, 11783 (1989).
- ¹⁸M. Gross, E. Sánchez-Velasco, and E. D. Siggia, Phys. Rev. B **40**, 11328 (1989).
- ¹⁹See, for instance A. Auerbach, *Interacting Electrons and Quantum Magnetism* (Springer-Verlag, New York, 1994), and references therein.
- ²⁰D. C. Mattis, *The Theory of Magnetism I: Thermodynamics and Statistical Mechanics* (Springer-Verlag, Berlin, 1988).
- ²¹S. L. Adler, Stud. Hist. Philos. Mod. Phys. **34**, 135 (2003).
- ²²Because of a technicality we choose to use a state with two magnons instead of a single one. By doing so we ensure that our system stays in the subspace of zero total magnetization ($M=0$), which considerably simplifies the calculations without loss of generality.
- ²³Note that in a d -dimensional system the number of spins is $N=L^d$, where L is the linear extent of the system. So the energy scale for the lowest possible spin wave (magnon) excitation is J/L . However, the energy scale of the thin spectrum is $J/N=J/L^d$, and is thus—in any dimension higher than one—much lower than the magnon energy scale.